

Stepping motor driven stages, ideal for positioning of measuring instruments or inspection tools from which high stiffness and high precision are required.

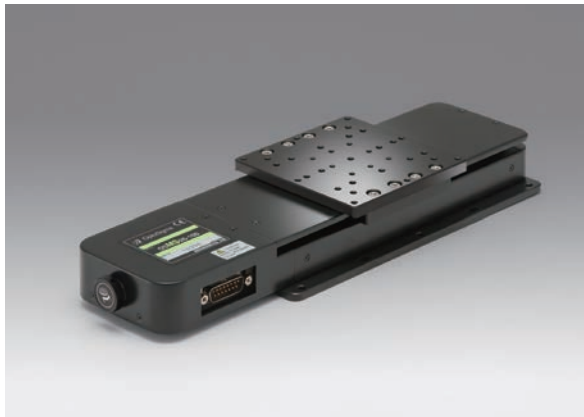

- U-shaped rail offers light weight, and minimized deflection to achieve high stiffness.

#### Guide

- ▶ Contact our Sales Division if you desire to change motors, etc.  
[Reference](#) G017, G123 (Motorized Stage System Question Sheet)  
[WEB Reference](#) [Catalog Code](#) W9500
- ▶ Grease change is optionally available.  
[Reference](#) G122 [WEB Reference](#) [Catalog Code](#) W9006
- ▶ We will assemble your X axis stage with a newly purchased X axis stage at a separate cost.

#### Specifications

Part Number		OSMS26-50(X)	OSMS26-100(X)	OSMS26-200(X)	OSMS26-300(X)	
Part Number (-M6)		OSMS26-50(X)-M6	OSMS26-100(X)-M6	OSMS26-200(X)-M6	OSMS26-300(X)-M6	
Part Number (-INCH)		OSMS26-50(X)-INCH	OSMS26-100(X)-INCH	OSMS26-200(X)-INCH	OSMS26-300(X)-INCH	
Mechanical Specifications	Travel [mm]	50	100	200	300	
	Stage Size [mm] (M6, INCH)	100×100 (120×120)	100×100 (120×120)	100×100 (120×120)	100×100 (120×120)	
	Feed Screw	Ball screw diameter $\phi$ 8mm, 2mm lead	Ball screw diameter $\phi$ 8mm, 2mm lead	Ball screw diameter $\phi$ 8mm, 2mm lead	Ball screw diameter $\phi$ 8mm, 2mm lead	
	Positioning Slide	Outer rail structure	Outer rail structure	Outer rail structure	Outer rail structure	
	Stage Material	Aluminum	Aluminum	Aluminum	Aluminum	
	Finish	Black anodized	Black anodized	Black anodized	Black anodized	
	Weight [kg] (M6, INCH)	2.7 2.9	3.1 3.3	4.1 4.4	5.0 5.4	
Accuracy Specifications	Resolution	(Full) [ $\mu$ m/pulse]	4	4	4	4
		(Half) [ $\mu$ m/pulse]	2	2	2	2
	MAX Speed [mm/sec]	40	40	40	40	
	Positioning Accuracy [ $\mu$ m]	5	10	15	20	
	Positional Repeatability [ $\mu$ m]	3	3	6	6	
	Load Capacity [N]	117 (12.0kgf)	117 (12.0kgf)	117 (12.0kgf)	117 (12.0kgf)	
	Moment Stiffness	Pitch [ $^{\circ}$ /N·cm]	0.23	0.23	0.23	0.23
		Yaw [ $^{\circ}$ /N·cm]	0.12	0.12	0.12	0.12
		Roll [ $^{\circ}$ /N·cm]	0.2	0.2	0.2	0.2
	Lost Motion [ $\mu$ m]	3	3	5	5	
	Backlash [ $\mu$ m]	3	3	3	3	
	Parallelism [ $\mu$ m]	50	50	50	50	
	Running Parallelism [ $\mu$ m]	10	10	10	20	
Pitch [ $^{\circ}$ ] / Yaw [ $^{\circ}$ ]	25/20	25/20	30/25	30/25		
Sensor	Sensor Part Number	Micro photo sensor: GP1S092HCPIF (Sharp Corporation)				
	Limit Sensor	Equipped (NORMAL CLOSE)	Equipped (NORMAL CLOSE)	Equipped (NORMAL CLOSE)	Equipped (NORMAL CLOSE)	
	Origin Sensor	Equipped (NORMAL OPEN)	Equipped (NORMAL OPEN)	Equipped (NORMAL OPEN)	Equipped (NORMAL OPEN)	
	Proximity Origin Sensor	Equipped (NORMAL OPEN)	Equipped (NORMAL OPEN)	Equipped (NORMAL OPEN)	Equipped (NORMAL OPEN)	

#### Motor / Sensor Specifications

Motor	Type	5-phase stepping motor 0.75A/phase (Oriental Motor Co., Ltd.)
	Motor Part Number	PK525HPB-C4(□28mm)
	Step Angle	0.72°
Sensor	Power Voltage	DC5 - 24V $\pm$ 10%
	Current Consumption	80mA or lower (20mA or lower per sensor)
	Control Output	NPN open collector output DC30V or lower, 50mA or lower
	Output Logic	When shaded: Output transistor OFF (no conduction) : Limit Sensor When shaded: Output transistor ON (conduction): Origin sensor, Proximity Origin Sensor

#### Compatible Driver / Controller

Control System	Compatible Driver	SG-5M, SG-5MA, MC-S0514ZU, SG-514MSC, MC-7514PCL
	Compatible Controller	GSC-01, GSC-02, SHOT-702, GIP-101, HSC-103, SHOT-302GS, SHOT-304GS, HIT-M·HIT-S, PGC-04-U

Application Systems

Optics &amp; Optical Coatings

Opto-Mechanics

Bases

Manual Stages

Actuators &amp; Adjusters

Motorized Stages

Light Sources &amp; Laser Safety

Index

Guide

Controllers/Drivers

Softwares

Stepping Motor

AC Servo Motor

Cables

Piezo

X Translation

Theta Rotation

Goniometer

Vacuum

Options

40 x 40 mm

60 x 60 mm

80 x 80 mm

85 x 85 mm

100 x 100 mm

120 x 120 mm

Others



**Outline Drawing**

**OSMS26-\*(X)** Hexagon socket head cap screw M4x10...10 screws (50, 100)  
Hexagon socket head cap screw M4x10...14 screws (200)  
Hexagon socket head cap screw M4x10...18 screws (300)

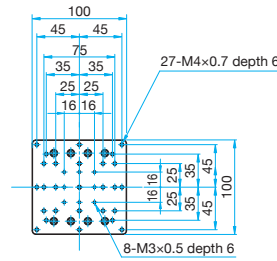
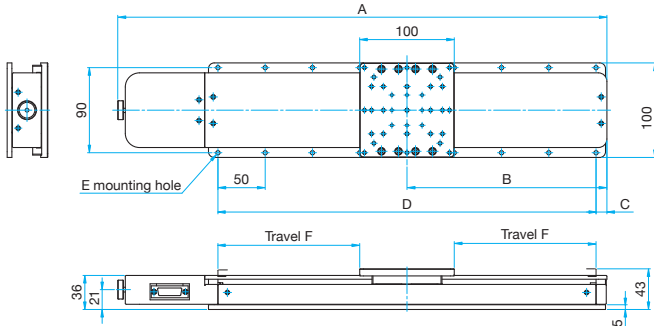

Part Number	A	B	C	D	E	F
OSMS26-50(X)	267.5	86.5	11.5	150 (25, 50x2, 25)	10-φ4.5	25
OSMS26-100(X)	317.5	111.5	11.5	200 (50x4)	10-φ4.5	50
OSMS26-200(X)	417.5	161.5	11.5	300 (50x6)	14-φ4.5	100
OSMS26-300(X)	517.5	211.5	11.5	400 (50x8)	18-φ4.5	150

**OSMS26-\*(X)-M6** Hexagon socket head cap screw M6x10...10 screws (50, 100)  
Hexagon socket head cap screw M6x10...14 screws (200)  
Hexagon socket head cap screw M6x10...18 screws (300)

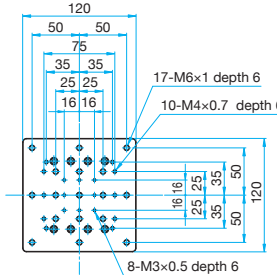
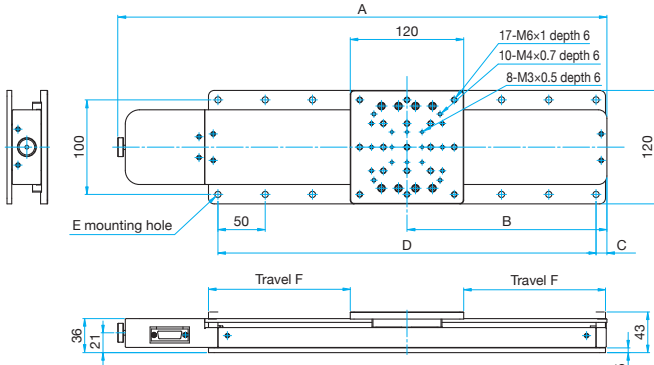

Part Number	A	B	C	D	E	F
OSMS26-50(X)-M6	267.5	86.5	11.5	150 (25, 50x2, 25)	10-φ6.5	25
OSMS26-100(X)-M6	317.5	111.5	11.5	200 (50x4)	10-φ6.5	50
OSMS26-200(X)-M6	417.5	161.5	11.5	300 (50x6)	14-φ6.5	100
OSMS26-300(X)-M6	517.5	211.5	11.5	400(50x8)	18-φ6.5	150

**OSMS26-\*(X)-INCH** Hexagon socket head cap screw 1/4-20UNCx3/8...10 screws (50, 100)  
Hexagon socket head cap screw 1/4-20UNCx3/8...14 screws (200)  
Hexagon socket head cap screw 1/4-20UNCx3/8...18 screws (300)

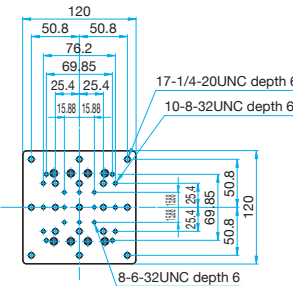
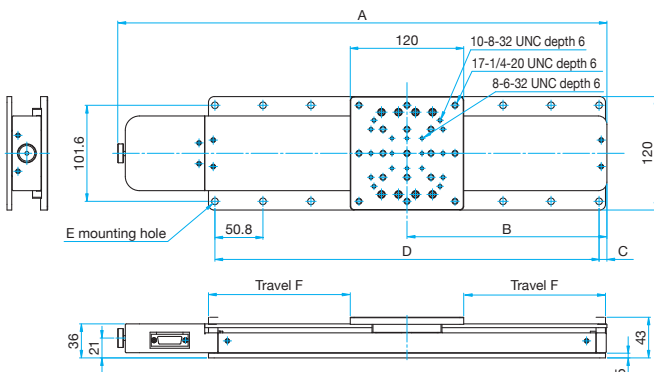

Part Number	A	B	C	D	E	F
OSMS26-50(X)-INCH	267.5	86.5	10.3	152.4 (25.4, 50.8x2, 25.4)	10-φ7	25
OSMS26-100(X)-INCH	317.5	111.5	9.9	203.2 (50.8x4)	10-φ7	50
OSMS26-200(X)-INCH	417.5	161.5	9.1	304.8 (50.8x6)	14-φ7	100
OSMS26-300(X)-INCH	517.5	211.5	8.3	406.4 (50.8x8)	18-φ7	150

**Connection Diagram**

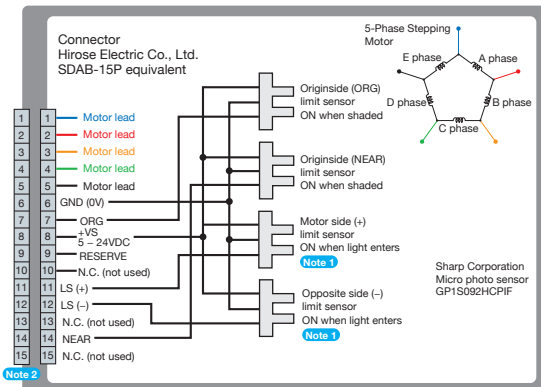

**Note 1** The motor side limit sensor is the + direction limit sensor.  
**Note 2** Compatible cable connector: DDK Ltd. 17JE-13150

**Compatible Controllers / Drivers and Cables**

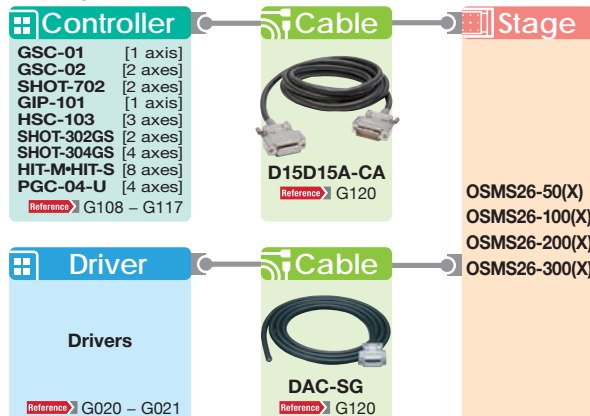

Application Systems

Optics & Optical Coatings

Opto-Mechanics

Bases

Manual Stages

Actuators & Adjusters

MotORIZED Stages

Light Sources & Laser Safety

Index

Guide

Controllers/Drivers

Softwares

Stepping Motor

AC Servo Motor

Cables

Piezo

X Translation

Theta Rotation

Goniometer

Vacuum

Options

40 x 40 mm

60 x 60 mm

80 x 80 mm

85 x 85 mm

100 x 100 mm

120 x 120 mm

Others